

MANN+HUMMEL
Europiclone® Line 45

MANN+
HUMMEL

Installation and Maintenance Manual



Contact information

This installation and maintenance manual is a component part of the scope of delivery. It must be kept in a safe place and remain with the equipment in the event of resale.

We reserve the right to make technical improvements to the products described in this installation and maintenance manual without notification.

Reprinting, translation and copying of this document, or extracts of it, by any means requires the written approval of the publisher.

Copyright remains with the publisher.

This installation and maintenance manual is not subject to an updating service.

Information on the current status is available from

MANN+HUMMEL GMBH
 Industrial Filters Business Unit
 Brunckstr. 15
 D - 67346 Speyer
 Internet: <http://www.mann-hummel.com/>
 E-mail: if.info@mann-hummel.com

Contents

| | | |
|----------|--|-----------|
| 1 | Foreword | 2 |
| 2 | Scope of Delivery | 2 |
| 3 | Safety | 3 |
| 3.1 | Warning labels and symbols | 3 |
| 3.2 | Intended use..... | 3 |
| 4 | Function Description | 3 |
| 5 | Installation | 5 |
| 5.1 | General information..... | 5 |
| 6 | Maintenance / Repair | 7 |
| 6.1 | Maintenance of the main element | 8 |
| 6.1.1 | Disassembling the main element..... | 8 |
| 6.1.2 | Cleaning the main element | 9 |
| 6.1.3 | Installing the main element | 10 |
| 6.2 | Maintenance of the secondary element ... | 11 |
| 6.2.1 | Disassembling the main element..... | 11 |
| 6.2.2 | Changing the secondary element..... | 11 |
| 6.2.3 | Installing the main element | 12 |
| 6.2.4 | Maintenance of the dust discharge valve | 13 |
| 6.2.5 | Storing Filter Elements..... | 13 |
| 7 | Troubleshooting | 13 |
| 8 | Disposing of Parts | 15 |

1 Foreword

This installation and maintenance manual should help you become familiar with the Europiclon® and its intended use.

The installation and maintenance manual contains important information on operating the components safely, properly and economically. Observation of the manual helps avoid potential risks, reduce repair costs and downtimes as well as improve machine reliability and increase its service life.

The manual must be available to every person charged with working on the filter.

Where necessary, this manual must be supplemented by instructions containing existing national laws on accident prevention and environmental protection (particularly in respect of disposing of disassembled parts).

We reserve the right to make technical modifications to the filter and/or alter the content of this installation and maintenance manual without notification.

Information for the operator:

The operator is responsible for the provision of working equipment complying with basic health and safety requirements in accordance with the Ordinance on Industrial Safety and Health. This also includes deploying the work equipment such that it is only used within the scope of its intended use. The operator can define individual maintenance and service plans and intervals in addition to those stipulated in the installation and maintenance manual.

2 Scope of Delivery

The delivery contains the 2-piece air filter housing with main filter element and dust discharge valve. The filter is delivered fully assembled.

The maintenance indicator, secondary filter element and holder are optionally available and, therefore, not automatically supplied as a component part of the delivery. Compare the part number on the delivery with that in our catalogue. Order the parts later, if necessary.

3 Safety

3.1 Warning labels and symbols



This symbol appears in all the sections of the manual in which your safety could be at risk. Failure to observe the information provided could put persons at risk.



This symbol appears in all the sections of the manual in which the information provided must be strictly observed to prevent damage or destruction of system parts.

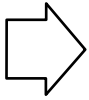

This symbol appears in all the sections of the manual in which the information provided must be carefully observed to ensure trouble-free, economic operation.

3.2 Intended use

The filter may only be maintained by appropriately trained, authorised personnel.

The Europiclon® has been constructed according to state-of-the-art technology and accepted safety-related regulations. However, the functional safety of connected equipment can be at risk when:

- the Europiclon® is improperly used,
- the operating conditions have changed,
- reconstructions have been made without prior consultation with the manufacturer,
- necessary maintenance and repair work has been neglected.

Den Europiclon® may only be used when it is in a technically safe working condition and for its intended use, taking the relevant technical design, safety and risk aspects into account and observing the information in the installation and maintenance manual! Investigate faults (or have them investigated) immediately, particularly those which could impair safety!

The Europiclon® has been exclusively designed for the mechanical filtration of air. Any other use above or beyond this, such as

filtering aggressive, combustible and/or explosive materials, is considered unintended use.

The manufacturer/supplier is not considered liable for damage resulting from unintended use.

Intended use also includes observing the information in the installation and maintenance manual and meeting all the inspection and maintenance conditions.

The operator is obliged to inspect the Europiclon® once a week for visible signs of damage and defects and to report any changes (including those in the operating behaviour) which could affect functional safety immediately.

All labels and identifications on the Europiclon® must be kept in a legible condition.

4 Function Description

The Europiclon® is a two-stage, dry air filter for cleaning the intake air of air aspirating machines of all types (e.g. engines, compressors, fans).

The intake air is circulated inside the filter housing by means of the tangentially arranged air intake spigot.

The centrifugal forces produced here force the heavy particulate matter outwards against the housing wall and discharge it via the dust discharge valve into the bottom housing section.

This initial filtering process (1st filter stage) means that the Europiclon® is particularly suited for applications involving higher concentrations of dust.

The cleaned air then flows through the main filter element (2nd filter stage) and downstream secondary element (option) to the air discharge spigot. The filter elements form a seal when assembled due to their shape. This radial seal provides the following advantages:

- minimal assembly and disassembly forces,
- minimal pressure exertion on the paper bellows,

- compulsory assembly of the secondary element via the main element,
- compulsory assembly of the main element via the bottom housing section,
- length tolerances are compensated for by the large overlap of the sealing surfaces => increased protection against penetration by dust.

The maintenance indicator/switch (option), connected to the adapter, indicates when the vacuum produced by the suction has exceeded a prescribed value (e.g. -60 mbar). This means that the prescribed maximum filter flow resistance value has been exceeded and the main filter element must be changed.

Europiclon® filters with a "1" as the last digit in the part number are delivered ex-works with an additional secondary element.

This prevents particulate matter getting into the engine during maintenance or when operating the system with a main element damaged through improper handling.

Europiclon® filters can be retrofitted with a secondary element at any time.

Vacuum models of the Europiclon® filters are equipped with an additional seal between the top and bottom housing sections.

The bottom housing section is available in five different models:

- with small dust discharge valve for engines with heavy pulsation (generally aspirated engines with up to 4 cylinders).
- with large dust discharge valve for engines with weak or no pulsation (generally engines with 5 or more cylinders, charged engines).
- with adapter for ejector extraction (for extreme dust contamination).
- with adapter for ejector extraction and integrated non-return valve.
- with shield valve for engines with heavy pulsation and for restricted installation conditions.

Wire clamp fasteners fix the bottom housing section to the top housing section.

A plastic holder with tensioning spring made of stainless steel fixes the Europiclon® in place and prevents it from turning.

The top housing section can be fixed in the holder at several locking positions in radial as well as longitudinal direction.

The intake neck can be fitted with an optional rain cap to protect it from rainwater and snow.

5 Installation

5.1 General information

Check that the scope of delivery is complete and that there are no signs of damage.

If parts delivered are damaged, inform your sales partner.

- Install the holder (1) in the required position
- Insert the filter in the holder and turn or move to the required installation position. Pay attention that the filter latches into place in the holder (1) (refer to Fig. 2).
- Fold the tensioning spring shut and latch into place on the closure side.
- The standard fixture of connecting parts to dirty air and clean air port must be made with heavy hose clamps compliant with DIN 3017.



It must be possible to lock the tensioning spring in place by hand, without the need for any tools. Otherwise, check the position of the filter again.



In the case of models with a dust discharge valve and horizontal installation position, the dust discharge valve must point downwards (a $\pm 15^\circ$ deviation to the "OBEN/TOP" mark (2) is permissible); if necessary, remove the bottom housing section, turn it to the required position and replace it.

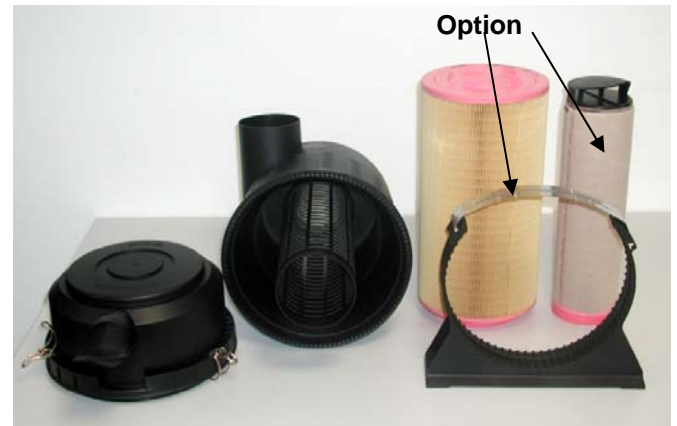

Fig. 1 Scope of delivery



Fig. 2 Installation angle, dust discharge valve



To open the tensioning spring, insert a screwdriver between the tensioning spring and holder on the closure side and lever the tensioning spring up (refer to Fig. 3).

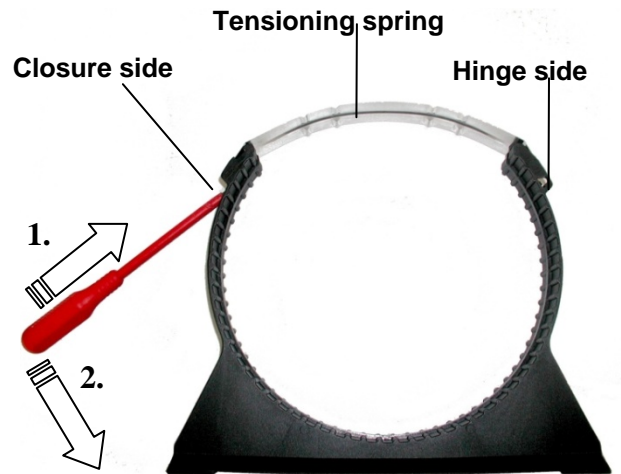

Fig. 3 Opening the holder

6 Maintenance / Repair



Cleaning, maintenance and repair work may only be carried out when the assembly is switched off (engine, compressor, fans, etc.).

Never start up with the filter element disassembled.

| Component | Activity | Time for maintenance |
|---|--|---|
| Main element | Change (If it cannot be changed, the main filter element can be cleaned in emergencies as described in Chapter 6.1.2) | in accordance with the operating manual supplied with the respective devices or engines, after the maintenance indicator/switch has been triggered or after 2 years at the latest |
| Secondary element (option) | Change | After 5 maintenance routines on the main element or after 2 years at the latest |
| Check raw and clean air lines (connection hoses) | For signs of damage/leaks | Monthly and after repair work |
| Connecting parts for dirty and clear air line (hose clamps) | Check for correct seating | Monthly and after repair work |
| Line from air filter to ejector (is installed) | For signs of damage/leaks | Monthly and after repair work |
| Dust discharge valve | Check for signs of damage/the function and clean | According to the dust concentration in the immediate environment (e.g. daily in the case of extreme dust accumulation) |
| Plastic housing and holder | Check for signs of damage and cracks | During filter maintenance |
| Maintenance indicator/switch (option) | Check function ¹⁾ | Annually |

¹⁾ To achieve the maximum permissible vacuum in the air intake system, the intake opening must be reduced in size slowly by covering it (e.g. with a piece of carton or metal plate) while the engine is running until the maintenance indicator/switch is triggered.

The air intake opening must not be reduced further in size after the maintenance indicator/switch has been triggered to prevent any damage being caused.

If leak tests must be carried out using higher pressure or vacuum levels, the maintenance indicator/switch must be disassembled for the period of the test and the connection on the filter sealed.

Reset the maintenance indicator after the check by pressing the Reset button.

6.1 Maintenance of the main element

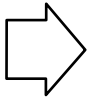

Maintenance of the main element (Pos. 2) need only be performed when the maintenance indicator/switch has been triggered, after 2 years at the latest or according to the device or engine manufacturer's instructions.

6.1.1 Disassembling the main element

- Unlock the wire clamp fasteners (1) and remove the bottom housing section (2) (refer to Fig. 4).

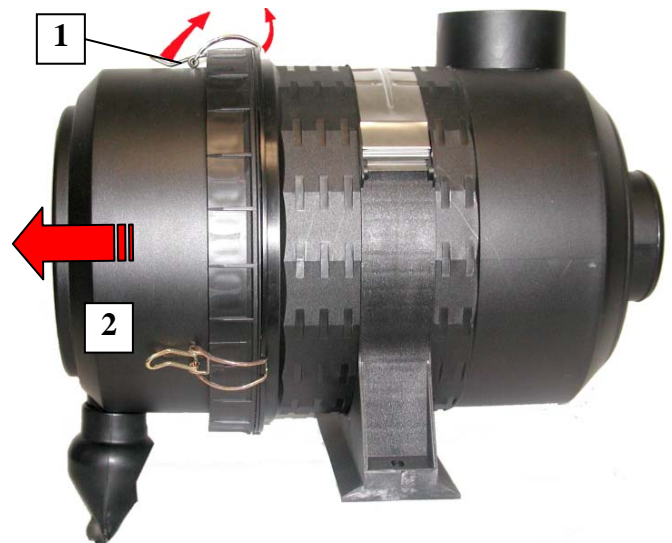

Fig. 4 Removing the bottom housing section

- Pull the main filter element (3) from the inner seal seat fully, turning slightly (refer to Fig. 5).



Wipe the inside of the housing thoroughly with a damp cloth. Pay attention here that no dust or dirt gets into the clean air side of the filter.



Fig. 5 Removing the main filter element

6.1.2 Cleaning the main element



Never wash, brush or beat the main element clean. **Only blow clean in emergencies**, paying attention that no dust gets into the inside of the main element.

The main element can be cleaned as described below in emergencies.



Since small defects are difficult, or even impossible to detect, we recommend new elements are always installed in order to protect engines or devices! We assume no liability if cleaned elements are reused.

To clean the main element, fit a tube (1), whose end is bent approx. 90°, on a compressed air gun (2). The tube must be sufficiently long to reach the bottom of the main element.

Clean the main element with dry compressed air (**maximum 5 bar**) carefully by moving the tube up and down in the main element, blasting the air from the inside to the outside until no more dust escapes (refer to Fig. 6).

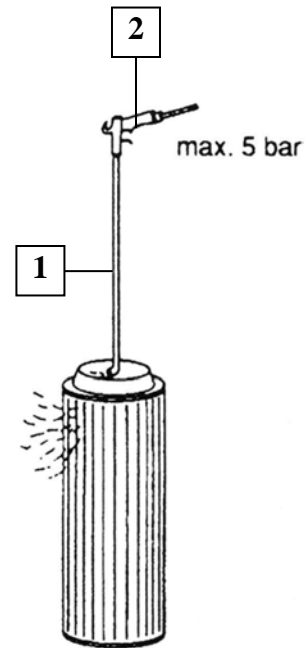

Fig. 6 Blowing the main filter element clean



The tip of the tube does not come into contact with the filter paper.



Before the cleaned main element is reinstalled, it must be checked thoroughly for signs of damage to the paper bellows and the rubber seals.



Check each fold of the paper bellows for cracks and holes using an appropriate inspection lamp (1) (refer to Fig. 7). In order that smaller damage is also detected, do not complete the inspection in direct sunlight but in a darkened room, for example.

Regardless of the number or operating hours, main elements must be changed after 2 years at the latest.

Never reuse damaged main elements. In the case of doubt, always install a new main element.

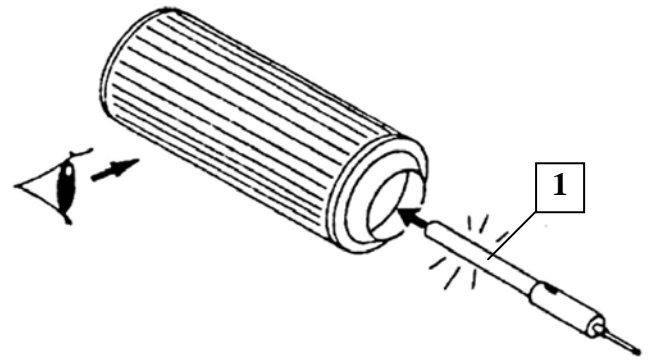

Fig. 7 Main filter element visual inspection

6.1.3 Installing the main element



Only use original MANN+HUMMEL elements! **Never** install elements with a metallic outer casing!

- Slide the main element (1) carefully into the housing with the open side at the front.
- In the case of vacuum models, check the seal between the top housing and bottom housing sections; change if necessary.
- Mount the bottom housing section (pay attention to the position of the dust discharge valve, also refer to Fig. 2).
- Mount the wire clamp fasteners in the slot in the flange on the top housing section and tension them (basically the reverse of Fig. 2).

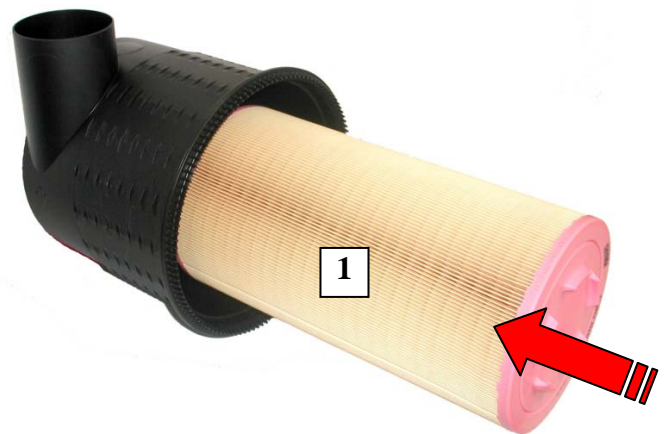

Fig. 8 Installing the main element



If the lid is not positioned correctly or no filter element has been inserted, the locking clips cannot be closed fully!



In no circumstances remove the support tube (2) fixed to the housing. The support tube is essential for reliable operation of the filter.



Fig. 9 Support tube

6.2 Maintenance of the secondary element

The secondary element (available as an option) must be changed every 3rd - 5th maintenance routine on the main element or after 2 years at the latest.

The secondary element must be changed at the authorized service center. This ensures that no particulate matter gets into the unit during the work.

6.2.1 Disassembling the main element

Refer to Chapter 6.1.1

6.2.2 Changing the secondary element



The secondary element must not be cleaned nor reused after being disassembled.

Disassemble the secondary element according to the model installed:

Model A:

- Take hold of the secondary element (1) by the grip (2) and pull out of the inner support tube (3) (refer to Fig. 10).

In no circumstances remove the support tube fixed to the housing. The support tube is essential for reliable operation of the filter.

- Slide the new secondary element on the support tube.

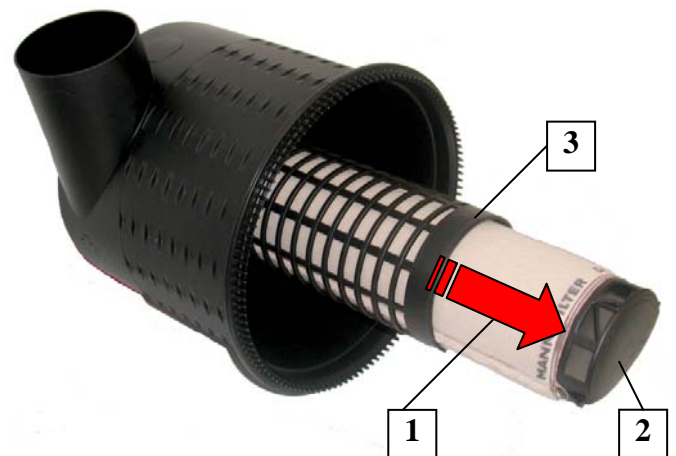

Fig. 10 Removing the secondary element (Model A)

Model B (only applies to size 100):

- Pierce through the seal (webbing) of the secondary element using a suitable tool (e.g. screwdriver) from the inside to the outside and pull up the two tabs (refer to Fig. 11). **Only open the seal (webbing) to change the secondary element.**
- Take hold of the secondary element by both tabs and pull out, turning slightly to and fro (refer to Fig. 12).

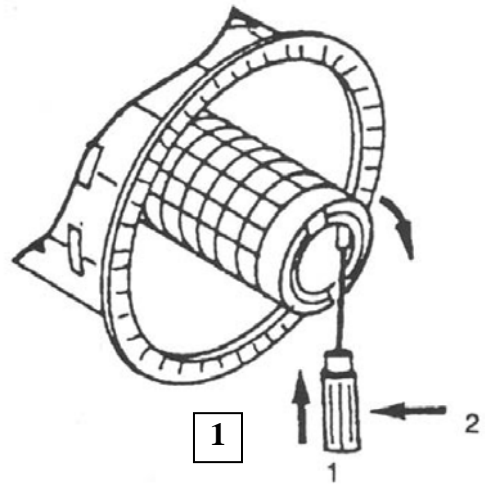

Fig. 11 Opening the seal (Model B)

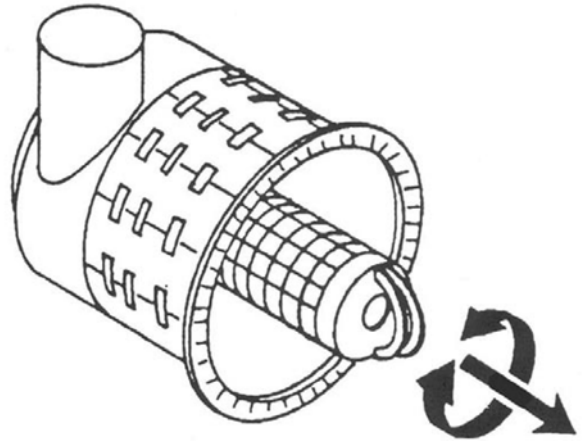

Fig. 12 Removing the secondary element (Model A)

6.2.3 Installing the main element

Refer to Chapter 6.1.3

6.2.4 Maintenance of the dust discharge valve

Dust discharge valve are generally maintenance-free.

The dust discharge valve (1) must be checked according to the local dust concentration, daily in the case of extreme dust accumulation. Any caked dust deposits must be removed by pressing the rubber lips of the valve together (refer to figure). The valve must be in free space. It must not come into contact with anything. Damaged valves must be replaced.



Fig. 13 Dust discharge valve

6.2.5 Storing Filter Elements



Protect stored filter elements from the effects of dust, moisture and damage. It is preferable to keep them in their original packaging.

It is practical to keep at least one spare element in stock for each filter element used. The function of the stored filter element is only guaranteed for up to 3 years following purchase.

7 Troubleshooting

| Error / Fault | Cause | Solution |
|---|--|--|
| Dust accumulation in bottom housing section | Dust discharge valve blocked or defect | Service valve (refer to Chapter 6.2.4), change, if necessary |
| Dust on clean side downstream from filter | Lines and/or connections on clean side downstream from filter leak | Remove dust thoroughly, seal lines and connections |
| | Connection point (on clean air side) not fixed correctly | Use hose clamps compliant with DIN 3017 and check for correct seating |
| Dust on clean air side in or downstream from filter | Main element defect | Remove dust thoroughly, check main element and change with secondary element, if necessary (refer to Chapters 6.1 and 6.2) |

| | | |
|--|---|--|
| | Incorrect maintenance | Remove dust thoroughly, complete maintenance in accordance with Chapter 6 |
| | Housing not closed correctly | Remove dust thoroughly; check main element, housing and closures for signs of damage; if necessary, replace components and close housing properly (refer to Chapter 6.1.3) |
| | Incorrect main element and/or secondary element installed | Remove dust thoroughly, install original MANN+HUMMEL filter elements |
| Maintenance indicator/switch (option) is not triggered despite heavily soiled filter element | Maintenance indicator/switch defect | Check maintenance indicator/switch (refer to Chapter 6, Footnote Maintenance Plan), replace as necessary and check again |
| | Lines, housing and/or main element leak or damaged | Clean the clean side thoroughly, eliminate leaks, replace damaged parts |
| Maintenance indicator/switch (option) always triggers | Main element worn out | Change main element (refer to Chapter 6.1) |
| | Secondary element worn out | Change secondary element (refer to Chapter 6.2) |
| | Maintenance indicator/switch defect | Replace maintenance indicator/switch |

8 Disposing of Parts

| Component | Material | Disposal |
|--------------------------|--|---|
| Main element | Filter paper Polyurethane foam | Dispose of according to local regulations |
| Secondary element | Filter paper / Fleece (according to model) Polyurethane foam / Adhesive PP – T20 | Dispose of according to local regulations |
| Top housing section | PP – T20 | Plastics recycling center |
| Bottom housing section | PP – T20 | Plastics recycling center |
| Wire clamp fasteners | Spring steel wire | Metal recycling centers |
| Holder | PA 6-GF30 | Plastics recycling center |
| Tensioning spring | 1.4310 stainless steel | Metal recycling centers |
| Adapter parts | TPO | Plastics recycling center |
| Seal (with vacuum model) | CR (neoprene) | Plastics recycling center |
| Dust discharge valve | NBR | Rubber recycling |

