

MANN +
HUMMEL

ScandMist 200R
Oil smoke filtration
system

ScandMist 200R

Oil smoke filtration system

General	Product	Units	ScandMist 200R
	Application		Neat Oil
	Capacity (nominal)	m ³ /h	2000
	Part number		A1B20RB000000A
Connections	Inlet type		Jacobs
	Inlet diameter	mm	315
	Drain		2 off, 2" Threaded (BS 21) Female
	Air inlet options		Left/Right
	Exhaust		Top free blow out and flange back side
Filters	Filters/stage		2
	Stage 1 filter		9709006037
	Stage 2 filter		9709006038
	Stage 3 filter		800530024917
	Available external pressure drop	Pa	200
Motor	Type		Electrically commutated
	Part number		9709005278
	Quantity		2
	Mains supply		3 - 380-480 V, 50/60 Hz
	Ventilation		TEFC
	Power	kW	2 x 3,7
	Maximum current	A	9,2
	Speed	RPM	Max 4100
	Environmental protection		IP54
Physical properties	Width	mm	770
	Height	mm	2000
	Depth	mm	1312
	Weight	kg	Clean filters: 370, Wet filters: 455
	Noise level	dB(A)	<69
	Fan		Backward bent blades
	Finish		Powder coating inside and outside
Controls	Control system		Micaflex MF-PFA
	Differential pressure gauges		3 off
Options	Oil pump		9708900071
	Level sensor		9908900187
	Prefilter demister		2500273212
	Spray		Not included
	Silencer		Insulated fan housing

EC fan and motor

The standard EC fan and motor delivers good energy efficiency with quiet operation.

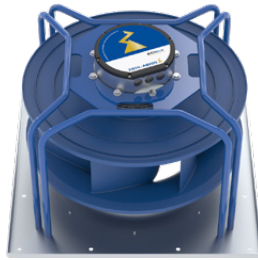

Connecting interface

Wiring via a Harting male/female connector. Quick and easy installation with all connecting interfaces at one spot.

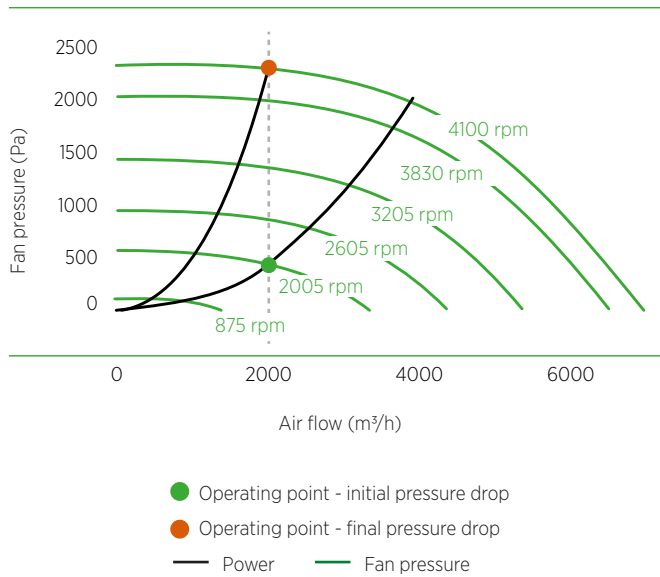

Power		Signal exchange	
1	L1	1	ON/OFF (make contact) Input: ON/OFF
2	L2	2	M
3	L3	3	Output Signal: In Operation Output: In Operation
4	N	4	M
5	PE	5	AL1 Alarm 1, Motor/Power
		6	M
		7	AL2 Alarm 2, System pressure high/low/operation signal
		8	N
		9	AL3 Alarm 3, System pressure high/low/operation signal
		10	N
		11	Reset Reset for alarms
		12	N
		13	AI2 Analog output 2 of Micaflex MF-PFA
		14	N

Dimensions and weight

Units: mm

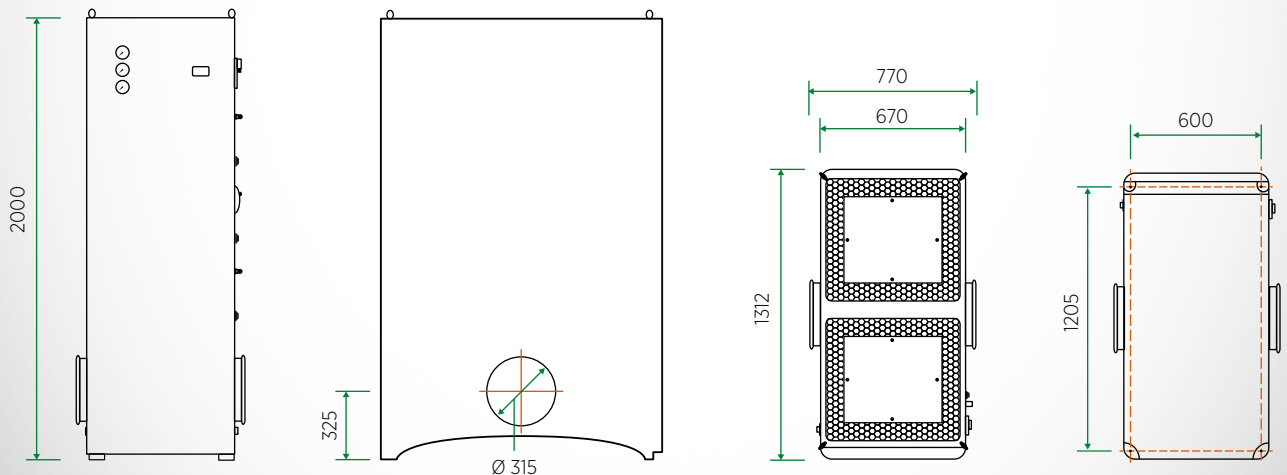

Weight	kg
Empty	260 kg
Clean filters	370 kg
Wet filters	455 kg



0419 Printed in Germany © MANN+HUMMEL